

O P E R A T I O N M A N U A L

WINCHESTER MODEL 1100XSU

Under Barrel Lever-Cocking Pellet Rifle



Use .177 cal. (4.5mm) LEAD AIRGUN PELLET 



WINCHESTER®

AIR RIFLES

A Product of Daisy Outdoor Products

This manual is intended for Winchester Air Rifles, distributed by Daisy Outdoor Products and does not apply to firearms bearing the Winchester name.



WARNING:

NOT A TOY. ADULT SUPERVISION REQUIRED. MISUSE OR CARELESS USE MAY CAUSE SERIOUS INJURY OR DEATH. MAY BE DANGEROUS UP TO 335 YARDS (306 METERS).

THIS IS A HIGH POWER AIR GUN RECOMMENDED FOR USE BY THOSE 16 YEARS OF AGE OR OLDER. READ ALL INSTRUCTIONS BEFORE USING. THE PURCHASER AND USER SHOULD CONFORM TO ALL LAWS GOVERNING USE AND OWNERSHIP OF AIR GUNS.

⚠ WARNING: THIS GUN CAN CAUSE DEATH. READ AND FOLLOW THE INSTRUCTIONS CAREFULLY. DO NOT LOAD A PELLET INTO THE GUN UNTIL YOU ARE READY TO SHOOT. IF YOU DO LOAD A PELLET AND THEN DECIDE NOT TO SHOOT, REMOVE IT EITHER MANUALLY OR BY SHOOTING THE GUN AT A SAFE TARGET. AN UNLOADED, UNCOCKED GUN IS SAFEST. ACCIDENTS HAPPEN FAST, AND ACCIDENTALLY INJURING OR KILLING SOMEONE IS A TERRIBLE THING. PLEASE SHOOT SAFELY.

⚠ This safety alert symbol indicates important safety messages in this manual. When you see this symbol, be alert to the possibility of personal injury and carefully read the message that follows.

The “Introduction to Winchester Air Rifle Shooting” section of this book which starts on Page 10, tells about the rules of shooting safety. **READ THIS SECTION.** Follow the safety rules and make certain anyone using your gun has been instructed in proper gun handling and safety. More power means greater chance of serious injury or death. Be sure to read the rules for “Proper Gun Handling” on Page 11.

The Model 1100XSU Winchester Air Rifle shoots with much more muzzle energy than most BB and pellet guns. Use extreme caution when operating this gun. Although your new Winchester Air Rifle is not a firearm, it has lethal potential and should be treated with the caution and respect due any conventional firearm. Like a firearm, your Winchester Air Rifle, when misused or carelessly used, can kill or seriously injure the shooter or other persons. Always remember, the first and most important safety feature of any gun is the shooter. All safeties are mechanical devices and the shooter is the only part of the system that can make a gun safe—or unsafe. **DON'T DEPEND ON MECHANICAL SAFETIES**—think ahead and avoid situations that might lead to accidents.

Guns differ in their operation, and you are never ready to fire any gun until you are thoroughly familiar with it. Read the following operating instructions and **WITHOUT LOADING ANY PELLETS**, proceed through the operating steps, dry firing your gun a few times at a safe target. **NOTE: Too much dry firing of the gun can cause excessive wear.** This will enable you to learn to operate the Winchester Air Rifle properly and safely.

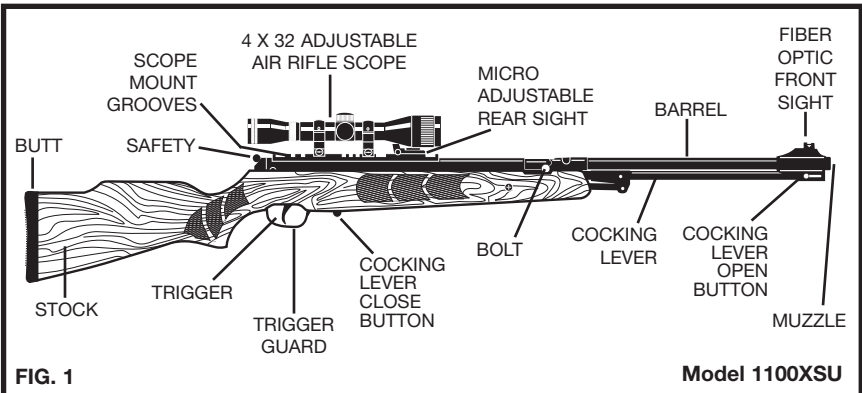

PRIOR TO OPERATION

Put “ON” safety. Push safety to forward-up position - NO RED DOT SHOWING (See Fig. 2a).

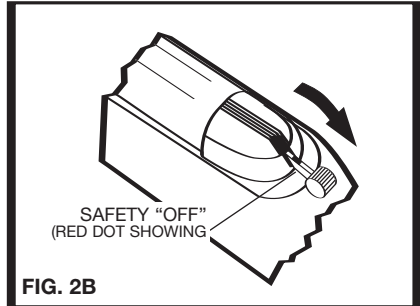
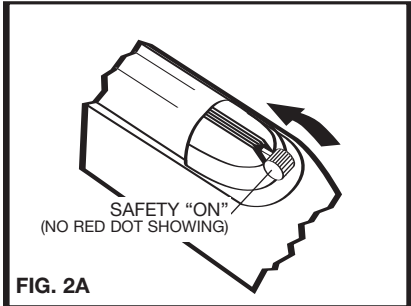

OPERATING STEPS

WARNING: Be sure the gun is always pointed in a safe direction. Never point the gun at anyone. Always assume and handle the gun as if it were loaded and ready to fire.

STEP 1. PUT “ON” SAFETY - NO RED DOT SHOWING (See Fig. 2a)

STEP 2. COCK (See page 4)

STEP 3. LOAD (See page 5)

STEP 4. AIM AT SAFE TARGET

STEP 5. TAKE “OFF” SAFETY - RED DOT SHOWING (See Fig. 2b)

STEP 6. FIRE (See page 6)

NEVER STORE A LOADED GUN

At the end of a shooting session, as a safety precaution, always put “ON” safety. (See Step 1, page 4), and unload pellet from rifle. (See instructions on page 6.) Store in a safe place to prevent unauthorized use.

WARNING: The following three points must be strictly followed. Failure to do so could result in the rifle failing to discharge a projectile although it may remain in the barrel. This could be a dangerous condition. Also, jamming or damage to the rifle could occur. See “WARNING” notation on page 6.

1. DO NOT use distorted or deformed pellets. Carefully check the skirt of each pellet before loading. Use only Daisy PrecisionMax brand .177 cal. (4.5mm) pellets for the Model 1100XSU pellet gun.
2. DO NOT load the pellets in backwards (i.e., DO NOT load pellets skirt forward. See Fig 5.)
3. DO NOT use BBs, buckshot, ball bearings or any other foreign objects.

HOW TO OPERATE

WARNING: Be sure the gun is always pointed in a safe direction. Never point the gun at anyone. Always assume and handle the gun as if it were loaded and ready to fire.

Step 1. PUT “ON” SAFETY

Push safety fully to the forward-up position – NO RED DOT SHOWING (See Fig. 2a).

NOTE: The safety resets when the gun is cocked, however you must always check to make sure the safety is on - NO RED DOT SHOWING. The safety will only do its job when you do yours. REMEMBER, THE BEST SAFETY IS GOOD GUN HANDLING.

Step 2. COCK (See Fig. 3)

1. Hold the gun firmly in an upright position with the butt resting on a solid surface.
2. Move the cocking lever open button (See Fig. 1) to the upward position. (Step 1)
3. Grasp the cocking lever firmly and push downward until a click is heard. (Step 2)
4. Push the cocking lever close button (See Fig. 1) inward. (Step 3)
5. Return the cocking lever to the upward position until it latches. (Step 4)

WARNING: When cocking the rifle do not place your hand over or in front of the muzzle. Don't allow the muzzle to point toward you or anyone else during cocking. Always keep the muzzle pointed in a safe direction.

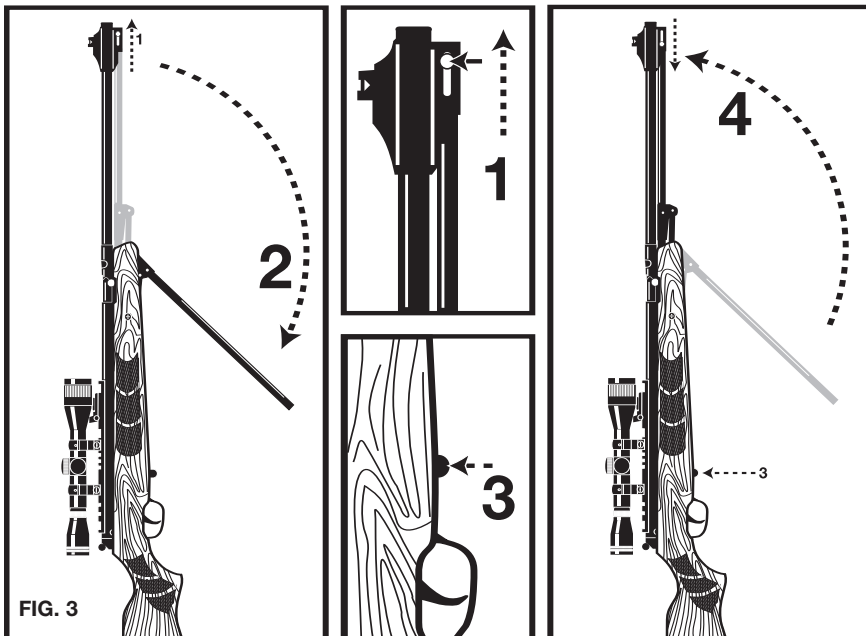

CAUTION: Be sure to grasp the cocking lever firmly as you cock it to prevent it from snapping back and possibly causing injury. Also, be careful to keep fingers out of cocking mechanism and between cocking lever and barrel when cocking or closing the cocking lever. (See “Pinch Points”, Fig. 4.)

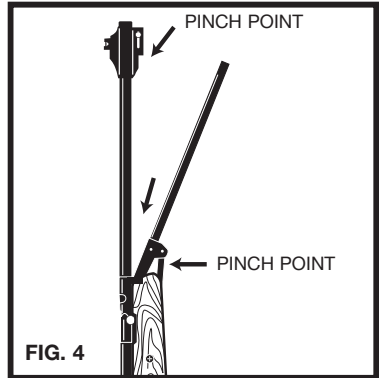

Step 3. LOAD (Figure 5)

1. Open the bolt by rotating counterclockwise and sliding forward toward the muzzle (A).
2. Insert a lead pellet (solid end forward) fully into the chamber at the breech end of the barrel. (B).
3. Close the bolt and rotate the bolt handle down to the fully locked position (C).

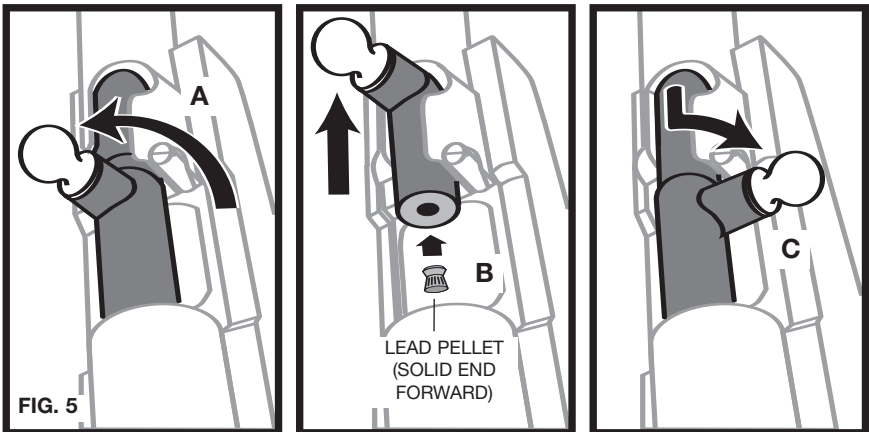

Step 4. AIM AT SAFE TARGET

Aim at a safe target. To be a consistent marksman, use the correct sight picture each time you fire the gun. (See Fig. 6.)



CAUTION: Due to the power of this gun, use extra caution in selecting a safe target backstop. This gun should not be used with BB gun target backstops. Pick targets that cannot be penetrated or that will not cause a ricochet because of their hard surfaces. Use only targets and traps that are designed for use with high-powered pellet guns. Do not shoot at water. See pages 14 and 15 on selecting a safe target.

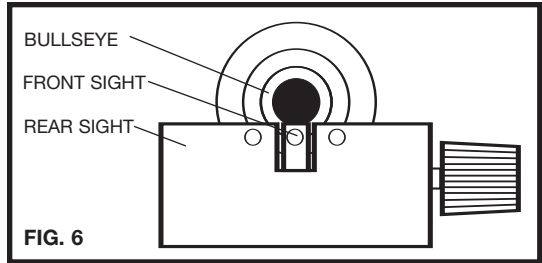

Step 5. TAKE “OFF” SAFETY

When you are certain that the target, backstop and surrounding area are safe, move the safety fully to the rear-down position – RED DOT SHOWING (See Fig. 2B). Your gun is ready to shoot. Pulling the trigger now will fire a pellet from the gun. In this condition, it should be handled with extreme care.

Step 6. FIRE

The rifle can be fired after completing the above operation steps. After making sure the gun is pointed in a safe direction, gently but firmly, squeeze the trigger.



WARNING: If a pellet does not fire after completing the operation steps, the gun may be jammed. An unfired projectile in the barrel can be a dangerous situation. Keep gun pointed in a safe direction and repeat all operation steps except Step 3. If a projectile still does not fire, do the following:

1. Put “ON” safety - NO RED DOT SHOWING. (See Fig. 2A)
2. Open the bolt and leave open with the safety on.
3. Clear barrel by running a cleaning rod through from muzzle end.
4. Repeat operation steps.

If after following the firing procedure the pellet does not fire, your gun should be returned to the factory. (See “Repair of Winchester Air Rifles”)

UNLOAD PELLET

It is preferable to fire the pellet at a safe target to unload the gun. If this is not practical, put “ON” safety, open the bolt and push the pellet from the chamber by running a cleaning rod through the muzzle end. Close the bolt, cock, take “OFF” safety and fire the gun in a safe direction.

REAR SIGHT ADJUSTMENT

Your gun is equipped with a fully adjustable fiber optic rear sight.

Windage: To move the point of impact to the right, move the sight by turning Knob in a clockwise direction. To move the point of impact to the left, move the sight by turning Knob in a counterclockwise direction. (See Fig. 7A)

Elevation: To move the point of impact up, move the sight by turning Numbered Dial counterclockwise. To move the point of impact down, move the sight by turning Numbered Dial clockwise. (See Fig. 7B)

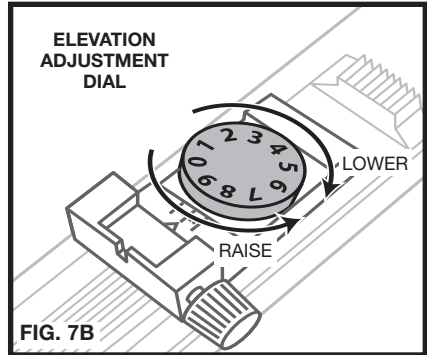
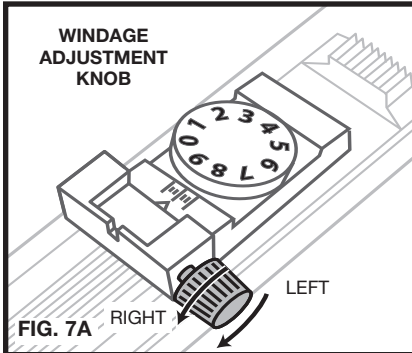

PROPER CARE

The exposed metal parts (rear sight, receiver, screw heads, sight hood, etc.) are a gun blue finish and **MUST** be wiped clean after handling to prevent rust. Use a soft cloth lightly oiled with a clean automotive motor oil.

The barrel hinge joint, cocking link hinge pins, air port seals, and latch plunger should be sparingly lubricated by occasionally adding a drop of clean, automotive motor oil. (See Fig. 8)



CAUTION: Never attempt to clean the gun until the gun is unloaded and the safety is "ON".

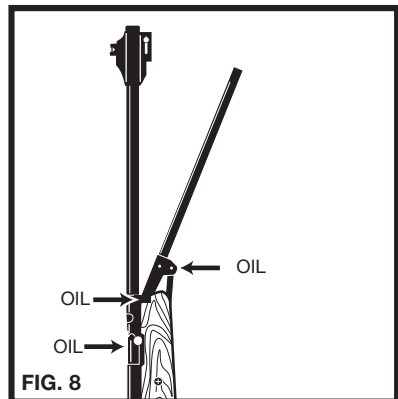

STORAGE

NEVER STORE A LOADED OR COCKED GUN. Put “ON” Safety and unload pellet from the gun. Keep rifle away from children and untrained shooters. Store pellets separately from the rifle to keep them from untrained shooters. Protect your rifle from moisture and dirt; clean gun and wrap it in a smooth, dry cloth, or store the gun in the package it came in when new.

MODIFICATION

 **CAUTION:** The components of this gun were engineered and manufactured to deliver optimum performance. Any modification or tampering with a gun may cause a malfunction and may make it unsafe to use. Any change in performance (such as a lowered trigger pull force and shortened trigger travel), indicates possible modification, tampering and/or wear. Such gun should be inspected, replaced or properly repaired by qualified personnel. Any gun that has been dropped should be checked by qualified personnel to ensure that its function has not been affected.

 **WARNING:** A GUN THAT IS NOT OPERATING PROPERLY MAY BE DANGEROUS. IT SHOULD BE KEPT SAFELY FROM USE BY ANYONE UNTIL REPAIRED OR DESTROYED. DO NOT TRY TO TAKE THE GUN APART. IT IS DIFFICULT TO REASSEMBLE, AND IMPROPER REASSEMBLY CAN CAUSE A HAZARDOUS CONDITION.

REPAIR OF WINCHESTER AIR RIFLES

GUNS IN WARRANTY LIMITED ONE-YEAR WARRANTY

For one year from date of purchase, Daisy will repair or replace and return this gun, free of charge, if defective in material or workmanship. Service is available by returning the gun to Daisy Outdoor Products (refer to important note below). Attach to the gun, your name, address, and telephone number, description of problem and proof of date of retail purchase (sales slip). Package and send transportation prepaid to Daisy. This Warranty gives you specific legal rights, and you may also have other rights which may vary from state to state.

IMPORTANT: You can return your inoperative rifle to Daisy for repair. We recommend returning guns via United Parcel Service. Be sure to put “ON” safety and unload ammo before returning the gun to Daisy. You must include your street address for Daisy to send your rifle directly back to you through UPS delivery.

GUNS OUT OF WARRANTY

If your Winchester Air Rifle needs repair, please call 1-800-713-2479 for repair charges. Daisy will repair the gun or replace it with a reconditioned gun of the same model, if available; otherwise, with a model of equivalent quality.

**Daisy Outdoor Products
Service Department
308 West Stribling Drive
Rogers, AR 72756**

SPECIFICATIONS - Model 1100XSU

ACTION	Under barrel lever-cocking spring air
CALIBER	.177 cal. (4.5 mm) lead air gun pellet
SIGHTS	TRUGLO® Fiber optic front TRUGLO® Fiber optic micro-adjustable rear
BARREL	Rifled Solid Steel
STOCK/FOREARM	Solid hardwood
CAPACITY	Single shot pellet
SAFETY	Auto Rear button
OVERALL LENGTH	46.5 in.
WEIGHT	8.75 lbs.
MUZZLE VELOCITY	1100 fps
MAXIMUM SHOOTING DISTANCE*	335 yds.

*With the muzzle pointed upward at the optimum angle.



WINCHESTER[®]

AIR RIFLES



Introduction to Winchester Air Rifle Shooting

A MESSAGE TO PARENTS

Included in the material accompanying each new Winchester Air Rifle is a checklist covering the most important aspects of proper gun handling. We urge you to use the checklist in assuring that anyone operating a Winchester Air Rifle has a thorough understanding of these rules and is diligent in their practice. Although not a firearm, a Winchester Air Rifle is a gun and not a toy. Like a firearm, when misused or carelessly used, your Winchester Air Rifle can kill or seriously injure the shooter or other persons. Properly used and maintained, it will provide many hours of safe, trouble free recreational shooting. Misused, it can be dangerous. Therefore, it should only be used only by adults or someone sixteen years of age or older under adult supervision.

As the proud owner of a new Winchester Air Rifle, you have become part of an American tradition dating back more than 100 years. Mechanically, a new Winchester Air Rifle is backed by nearly a century of engineering know-how and experience in the manufacture of quality products.

Safe gun handling depends upon proper safety training, and the right attitude toward gun ownership. To help you, we have designed this booklet to cover the basic facts everyone should understand before shooting a gun. Take time to study it thoroughly. A proper understanding of these basics will greatly increase your enjoyment of the lifetime sport of recreational air gun shooting and, at the same time, give you the satisfaction of knowing you are properly prepared to handle an air gun.

If you or your son or daughter (age 16 or older) becomes the owner of a Winchester Air Rifle, we strongly urge you to enroll yourself and them in a formal course of instruction in Shooting Education. Winchester Air Rifles are for adult shooters and those 16 years of age or older with adult supervision. There are a number of youth and civic organizations which offer a complete 10-lesson course based on guidelines developed by the training experts at Daisy, and they are listed in the section on CLUBS AND COMPETITION near the back of this book. A quick check with them will let you know when the next course will be starting in your area. If you would like more detailed information, write: Special Market Programs, Daisy, Box 220, Rogers, Arkansas 72757.

WHAT IS A WINCHESTER AIR RIFLE?

Backed by 100 years of engineering know-how, the design and craftsmanship of the Winchester Air Rifles has advanced to true gun levels. With up to ten times the power of traditional air guns, their sophistication in performance and operation have brought them to the attention of even the most serious sport shooters.

In recent years, sport shooters have begun to feel the squeeze of limited space and money for firearm shooting. The Winchester Air Rifles remove these limits for both the enthusiast who wants low cost shooting for year-round training, indoors or out, and dedicated shooters interested in shoulder-to-shoulder competition. With a Winchester Air Rifle, looks, heft and performance add up to adult size shooting right at your doorstep, and at a fraction of the cost of firearm shooting.

PROPER GUN HANDLING

You may be familiar with the responsibilities of proper gun handling, but the fact that your new Winchester air rifle has up to ten times the power of the traditional air gun means extra care is needed. In reviewing the basic rules of proper gun handling, keep in mind that "Handling" means every time you touch your gun.

- Always keep the muzzle pointed in a safe direction.
- Treat every gun as if it were loaded
- Only load or cock a gun when you are shooting
- Anyone shooting or observing a shooter should wear shooting glasses and should be standing behind the shooter.
- Never climb or jump with a loaded gun.
- Avoid ricochet.
- Keep the muzzle clear.
- Guns not in use should always be unloaded.
- Respect other people's property.
- Check your target and beyond your target.

Ninety percent of the air gun related accidents occurring in this country are caused by: (1) careless handling of the gun, (2) believing the gun to be empty when it is not, or (3) shooting at improper targets. All three causes can be eliminated if the shooter handles the gun properly.

YOUR WINCHESTER IS A TARGET GUN

Your Winchester Air Rifle has been designed for target shooting and is suited for use both indoors and out to help you develop your marksmanship skills. However, your Winchester Air Rifle produces greatly increased velocity and energy, so take care to prepare your target. Target traps designed for use with low-velocity (less than 350 feet-per-second) BB and pellet guns **should not be used with a Winchester Air Rifle**. Always use a target trap designed to prevent ricochet, and put extra reinforcement behind your target to compensate for the added power. (See "How to Make an Indoor-Outdoor Target," page 14.)

TIPS ON MARKSMANSHIP

Many people become proficient at gun handling without learning the basics of proper marksmanship. Yet, these basics are intended for one purpose—to increase your skills. If you haven't learned them, now is the time to start. If you have, this may serve as a timely review.

TRIGGER AND BREATH CONTROL

When you get right down to it, trigger control is simply knowing your gun. Get your sights in line. The moment you have the proper sight picture, squeeze the trigger. Never jerk the trigger or you will ruin your aim. To do this, you must know your gun well enough to exert enough pressure on the trigger to where it's just short of firing the gun. Then at the exact instant you wish, the trigger can be squeezed with as little disturbance to the sight picture as possible. Trigger control comes only with practice. Keep trying, you'll get it down to an art.

Breathing at the wrong moment can cause your body to move and your aim to go astray. So breathe properly. Prior to raising the gun to the shooting position, inhale deeply, then exhale partially with arm in shooting position. Hold the remaining breath until shot is fired.

If after about 7 or 8 seconds you haven't got the shot off, cock your arm back 90 degrees (muzzle up), relax and breathe normally for a few seconds. Then take your "aiming breath" and try again.

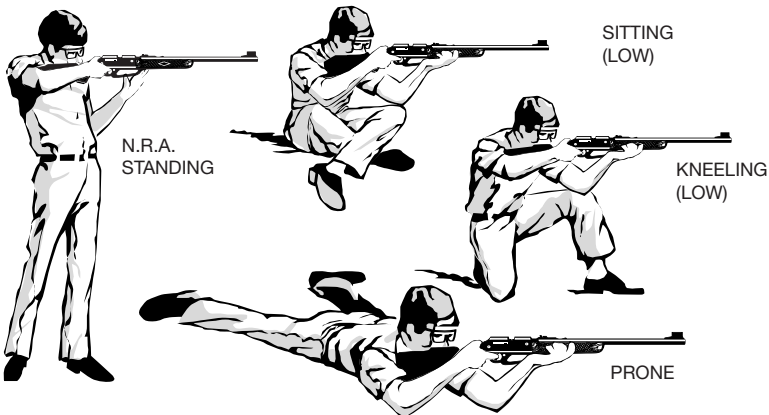

STANDING

- From a position directly facing the target, face to the right of the line of fire. The knees should be straight but not locked.
- Grasp the forearm of the gun in the left hand and place the butt of your gun in the shoulder pocket with the muzzle pointed upward.
- With the right hand, grasp the stock at the pistol grip, then press your cheek gently against the stock as far forward as possible without straining.

- Thrust the left hip forward, lower the gun to shoulder height, and with the left elbow directly under the gun, let the left upper arm rest against your body.
- The forearm of the gun should be supported in the palm of the left hand. (Thumb and fingertips, if using the NRA standing position.)
- Shift your weight to the left foot and lean your upper body away from the target. To assume the other positions:
(It should be noted again that left hand shooters reverse these directions when assuming the following positions.)

PRONE

- Half face to the right, then lie at an angle of about 45 degrees to the line of fire. The left leg should be completely relaxed. The right leg should angle away from the spine, and may be bent or straight. The feet should be as flat on the ground as possible.

SITTING

- Half face to the right, then in the low position, cross your legs in front of you with the outside of each foot resting on the ground and supporting the knees. Elbows should be placed near the knees, forming triangles to support the rifle.

In the high position, legs are not crossed; the feet are well spread, with the heels braced, and the body leaning forward so the elbows may be braced by the knees.

KNEELING

- Half face to the right and drop to the right knee. In the low position, the left foot should be extended as far forward as is comfortable, while the right leg is flat on the ground with the shooter sitting on the side of his foot. In the high position, the shooter sits on his right heel.

AIMING



WILL MAKE GUN SHOOT TOO HIGH



WILL MAKE GUN SHOOT TOO LOW



CORRECT SIGHT PICTURE

SIGHTING-IN YOUR GUN

The first step in proper sight alignment is to determine the shot grouping of your new Winchester Air Rifle. To do this, position a rest, such as a table or bench, 33 feet from your target. Place your rifle on the rest and aiming at the same point on the target each time, fire three shots. Do not attempt to make any adjustments during the three shots. At this point you are only interested in how well your shots group. Once you have determined the grouping ability of you and your pistol, you can then adjust your sights to bring the group on target. **NOTE:** It may be necessary for each person shooting your Daisy air gun to realign the sights to fit his sight pattern. **NOTE:** Some guns have fixed sights and cannot be adjusted.

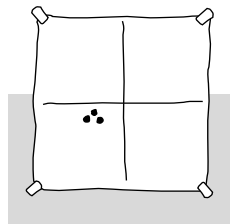

HOW TO MAKE AN INDOOR-OUT-DOOR TARGET

Because of the velocity and energy of your Winchester air rifle, care must be exercised in assuring that you have an adequate backstop for your target. A cardboard box 16 inches or more deep, and with at least two-foot square front surface, will serve as the basis for the target.

Center 3 inches of tightly bound magazines (do not substitute newspapers) on the inside back wall of the box opposite the target, and fill the box with tightly packed, crumpled newspaper to prevent ricochet. Once the backstop is complete, tape the target to the front of the box. **Do not use metal fasteners—BBs and pellets can ricochet.** As the target is used, the backing must be watched closely and should be replaced when the BBs or pellets have penetrated half the thickness of the magazines.

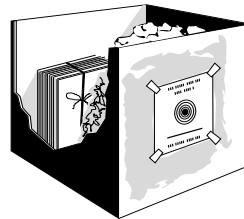

CAUTION: Whether you purchase a target trap or make your own, it is important to remember that **they will wear out** with continued use. Because of this, you should always place your backstop where it will be safe should it fail, and check it carefully before and after each use. A severe rebound or ricochet is an indication that the backstop is faulty and that you should stop using it immediately.

INDOOR SHOOTING

Inside as well as out, the rules of proper gun handling remain the same. If these rules are observed, your Winchester air rifle is safe for indoor shooting. Just remember to take the gun's power into account and carefully follow the instructions for constructing the target backstop.

The Power Line CO2 guns, the high performance Winchester air rifle spring-piston guns and the single pump pneumatic air guns deliver consistent maximum power; so make certain that the target backstop has been properly built.

For safety reasons, you must have the target placed so that there are not entry ways in front of or to the side of the firing line or behind the targets. If this is not possible, then doorways in the area should be blocked. A canvas or heavy blanket that is free from the wall and clears the floor should be hung behind the target backstop. This will prevent ricochet should you miss the backstop. Finally, your target should be well lighted.

Remember to keep your Winchester air rifle unloaded until the target is up and you are ready to shoot. **Never** point the gun in any direction except down range.

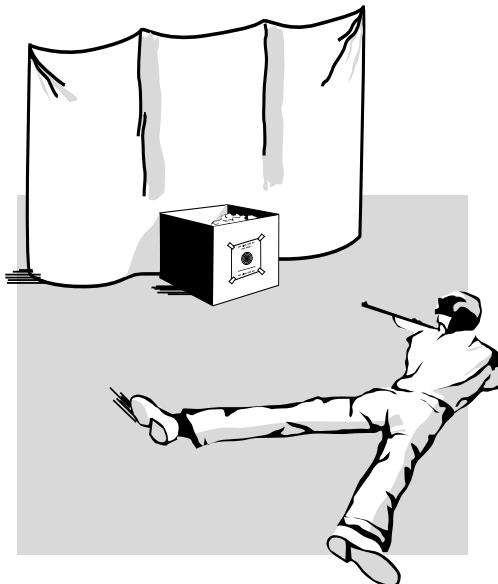

OUTDOOR SHOOTING

While your Winchester air rifle is excellent for outdoor shooting, its exceptional power means extra care is needed. The target backstop described on the preceding page will work equally well for outdoor shooting where space is limited. Be sure the target area is clear and safe before shooting.

USE THE RIGHT AMMUNITION

Winchester air rifles are designed to use various types of pellets only. Make certain you check the instructions stamped on your Winchester air rifle to assure that you use only the correct ammunition. If improper ammunition is used, your gun will not feed correctly and may jam, possibly resulting in serious injury. Because dirty and misshapen ammunition can jam your gun, DO NOT reuse BBs or pellets.

LEARN TO SHOOT SAFELY

Daisy Outdoor Products has a rich heritage of teaching young and first time shooters to shoot safely. In order to effectively implement shooting education programs nationwide, Daisy has partnered with the following organizations which teach shooting safety and provide additional shooting safety materials and information. We encourage you to contact Daisy at 1-800-643-3458 or one of these organizations to sign up for a shooting safety class in your area.

PROGRAM MATERIALS & EQUIPMENT

Daisy Outdoor Products

800-713-2479
www.daisy.com

PROGRAM INFORMATION

American Legion Junior Shooting Sports Program

317-630-1249
www.legion.org

NRA Youth Programs

800-672-3888 ext. 1505
www.nrahq.org/youth

Daisy / Jaycees Shooting Education Program

The United States Junior Chamber of Commerce
800-529-2337
www.usjaycees.org

4-H Shooting Sports

Contact your County Extension Agent
www.4-h.org

Junior Olympic Shooting Program

719-866-4670
www.usashooting.com